

Type 08

Installation Manual

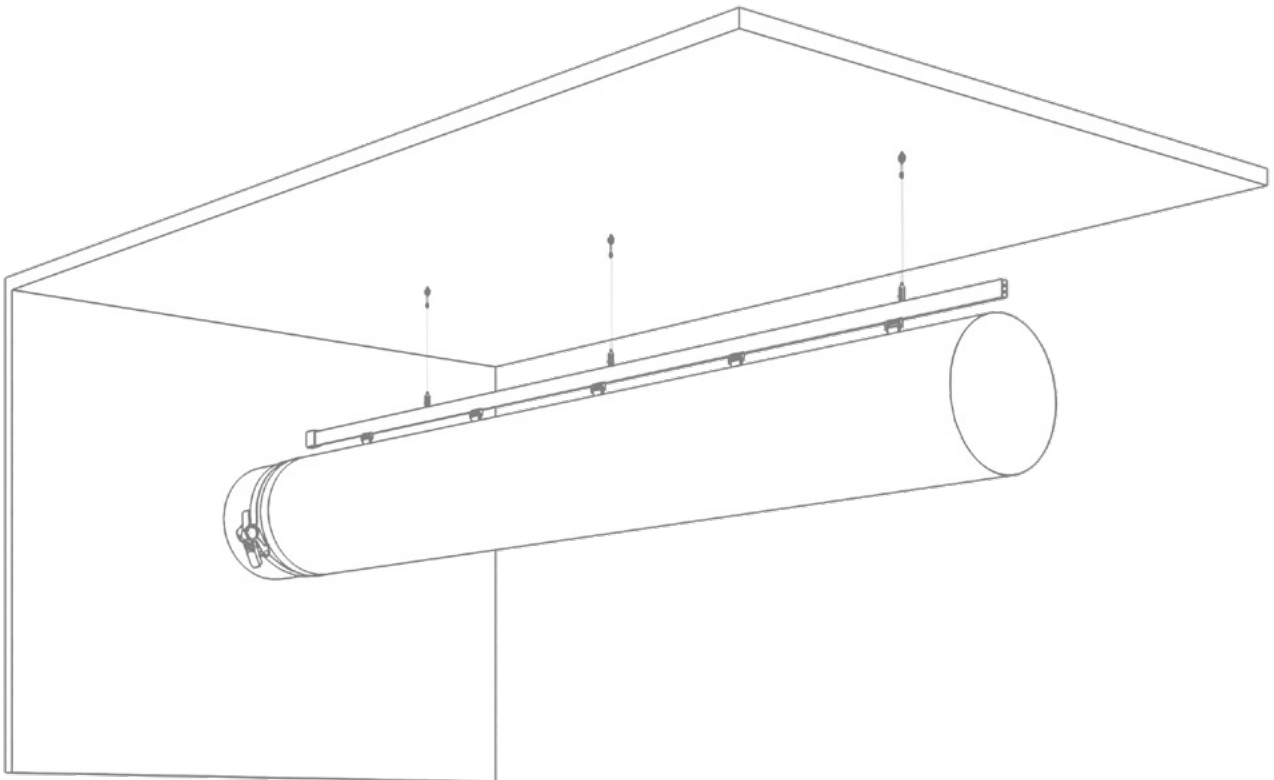

Type 08 suspension is compatible with classic, All-in-One and Internal 360° Hoops ducts.

Type 08 suspension is a suspended single H-Rail suspension with cables and adjustable cable locks connecting the H-Rail to the ceiling structure.

Content

1.0 OPENING PACKAGE	3
1.1 Understanding components table.....	4
1.2 Type 08 suspension components	5
2.0 SUSPENSION INSTALLATION	6
2.0 Suspension installation	6
2.1 Mounting H-Rail	6
2.2 Joining rails.....	8
2.3 Connecting additional profiles	8
2.4 Bendings.....	9
2.5 Detailed suspension installation.....	10
3.0 SHAPE RETAINING HARDWARE	11
3.1 All-in-One	11
3.2 Internal 360° Hoops assembly	12
3.3 Internal 360° Hoops disassembly	13
4.0 INSTALLING THE FABRIC	14
4.1 Connection to sheet metal part with fixing strap.....	14
4.2 Fixing straps.....	14
4.3 Installation of duct on H-Rail	15
4.4 Taut endcap installation	16

1.0 OPENING PACKAGE

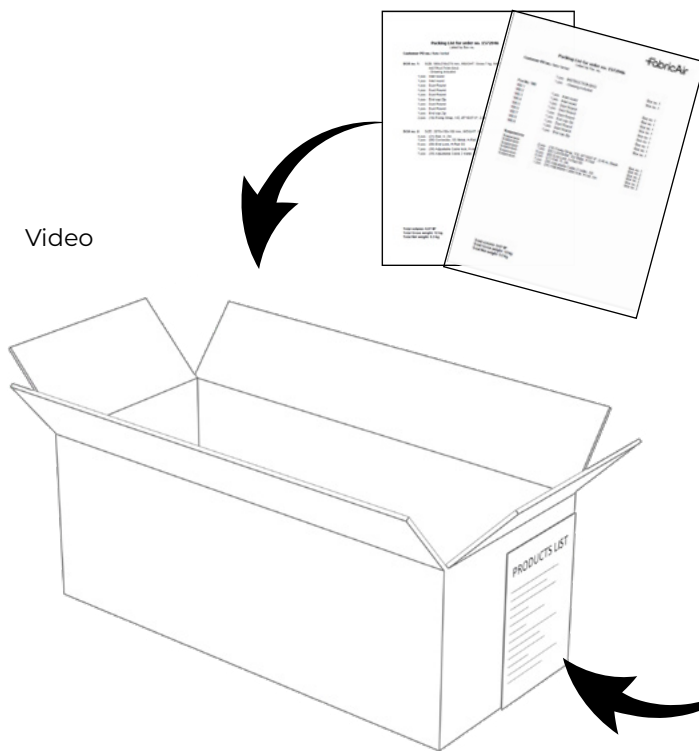

Box 1 includes all project documentation:

- System Drawing(s)
- Installation Guide
- Packing List (by box)
- Packing List (by positions)

Box number and contents list visible on external box label.

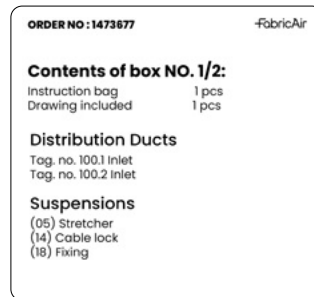

FabricAir		
Packing List for order no. 1572946 Listed by Pos. no.		
Customer PO no.: Nate Verbal		
	1 pcs INSTRUCTION BAG	Box no. 1
	1 pcs - Drawing included	Box no. 1
Pos No. 100		
100.1	1 pcs Inlet round	Box no. 1
100.2	1 pcs Inlet round	Box no. 1
100.3	1 pcs Duct Round	Box no. 1
100.4	1 pcs Duct Round	Box no. 1
100.5	1 pcs Duct Round	Box no. 1
100.6	1 pcs End cap Zip	Box no. 1
100.7	1 pcs Duct Round	Box no. 1
100.8	1 pcs Duct Round	Box no. 1
100.9	1 pcs End cap Zip	Box no. 1
Suspensions		
Suspension	2 pcs (18) Fixing Strap, Y/Z, Ø710/27.9", 2.46 m, Black	Box no. 1
Suspension	1 pcs (06) Connector, SS Metal, H-Rail	Box no. 2
Suspension	6 pcs (08) End Lock, H-Rail SS	Box no. 2
Suspension	4 pcs (21) Rail, H, 2m	Box no. 2
Suspension	7 pcs (38) Adjustable Cable 2 meter, SS	Box no. 2
Suspension	7 pcs (36) Adjustable Cable lock, H-rail, SS	Box no. 2
Total volume: 0.07 M ³ Total Gross weight: 12 kg Total Net weight: 9.3 kg		

FabricAir		
Packing List for order no. 1572946 Listed by Box no.		
Customer PO no.: Nate Verbal		
BOX no. 1:	SIZE: 590x210x275 mm, WEIGHT: Gross 7 kg, Net 5.9 kg.	
	INSTRUCTION BAG	
	- Drawing included	
	1 pcs Inlet round	Tag No. 100.1
	1 pcs Inlet round	Tag No. 100.2
	1 pcs Duct Round	Tag No. 100.3
	1 pcs Duct Round	Tag No. 100.4
	1 pcs Duct Round	Tag No. 100.5
	1 pcs End cap Zip	Tag No. 100.6
	1 pcs Duct Round	Tag No. 100.7
	1 pcs Duct Round	Tag No. 100.8
	1 pcs End cap Zip	Tag No. 100.9
	2 pcs (18) Fixing Strap, Y/Z, Ø710/27.9", 2.46 m, Black	Suspension
BOX no. 2:	SIZE: 2070x150x100 mm, WEIGHT: Gross 5 kg, Net 3.45 kg.	
	4 pcs (21) Rail, H, 2m	Suspension
	1 pcs (06) Connector, SS Metal, H-Rail	Suspension
	6 pcs (08) End Lock, H-Rail SS	Suspension
	7 pcs (36) Adjustable Cable lock, H-rail, SS	Suspension
	7 pcs (38) Adjustable Cable 2 meter, SS	Suspension
Total volume: 0.07 M ³ Total Gross weight: 12 kg Total Net weight: 9.3 kg		

- There are two packing lists – by box and by position. Each box may contain either suspension components or ducting. Each duct section/component has a Tag number (Tag No. XXX.X). Suspension elements have part ID numbers. Example: (21) H-Rail, 2 m. In this case, (21) is part ID.
- Tag numbers are marked in assembly sequence. Assembly of ducting should start with Tag No. XXX.1 and continue accordingly.

1.1 Understanding components table (located on system drawing)

COMPONENTS								
Tag#	Fabric	Color	Flow model			Suspension		
			Primary	Placement	Secondary	Type	Strap length	Material
350404600025	Combi 70	Black 3004			FabFlow		0	GV
100.1	Combi 70	Black 3004			FabFlow		0	GV
100.2	Combi 70	Black 3004	SonicFlow SonicFlow SonicFlow SonicFlow SonicFlow	2:00 3:00 4:00 5:00 6:00	FabFlow	Type 01 AiO	50 mm [2"]	GV

THE CHART SHOWN ABOVE IS AN EXAMPLE

Tag#: the unique number for that section, this is the identifying/unique number for that section.

Tag 3504..##..25: this part is the FabricAir flow straightener that helps manage turbulence and can be zipped into any joint.

Fabric: the fabric selected for this project.

Color: the color selected (standard meaning to select from the standard color chart for that fabric).

Flow model primary: primary dispersion method.

Placement: position of the holes; direction of airflow based on looking in the direction of airflow with the air hitting you from behind.

Flow model secondary: FabFlow for permeable fabrics.

Suspension type: the suspension model selected for the project.

Strap length: the length of the strap from the top of the duct to the suspension.

1.2 Type 08 suspension components (located on packing lists)

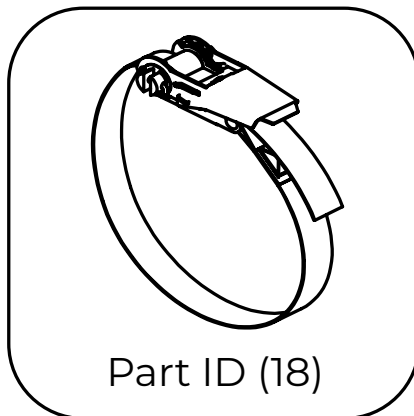
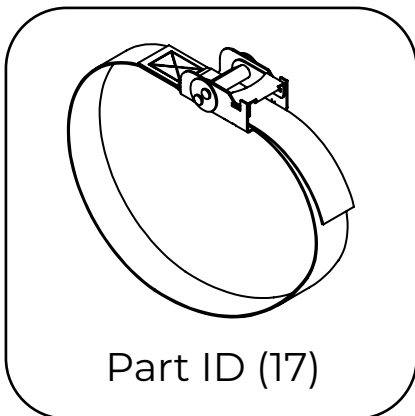
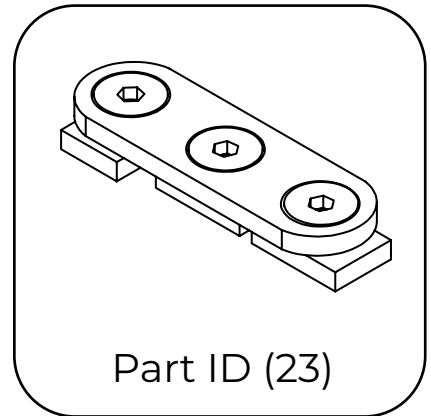
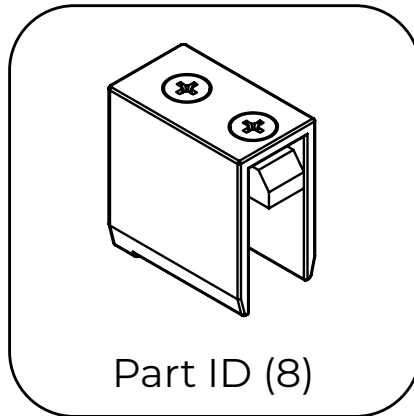
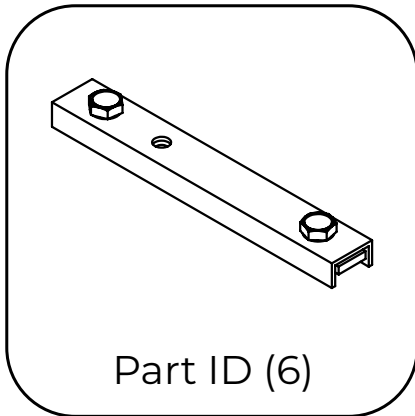
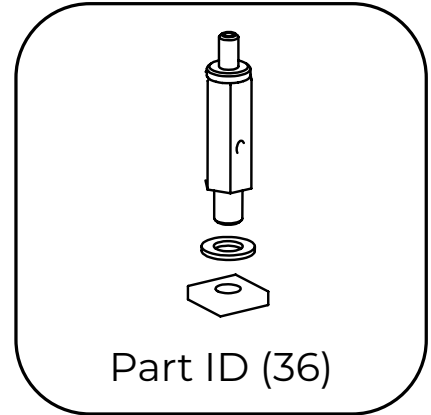
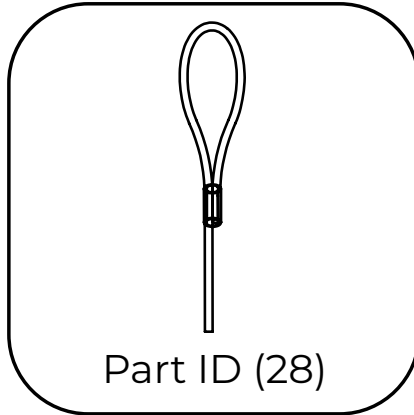
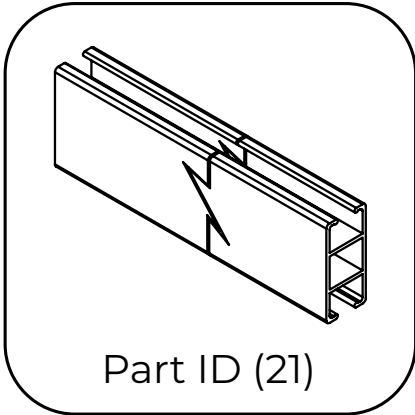

2.0 SUSPENSION INSTALLATION

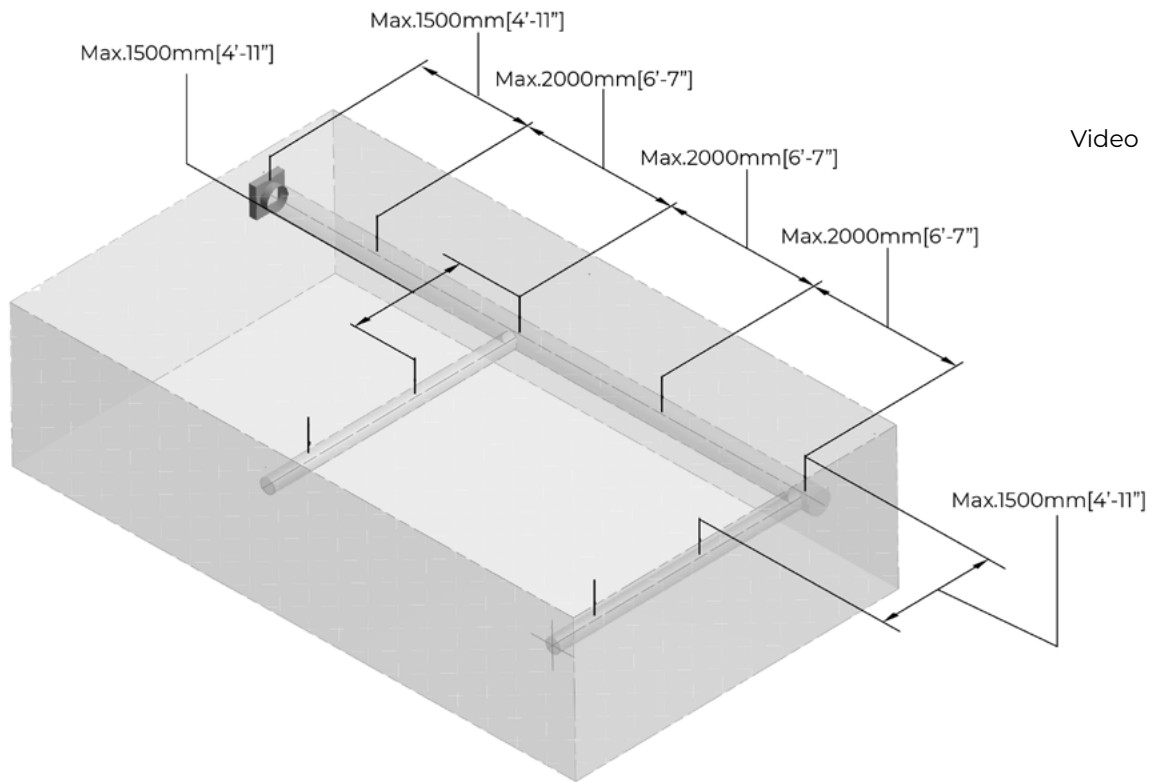

2.1 Vertical hangers

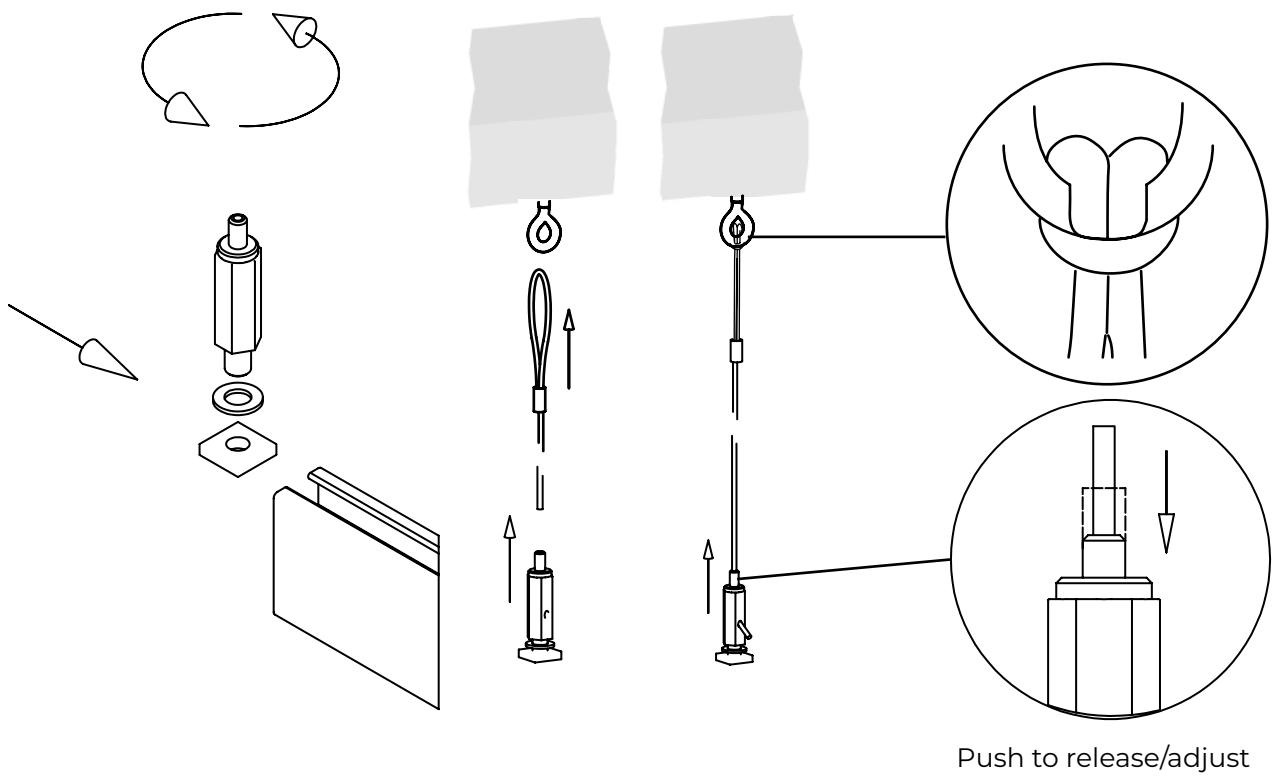

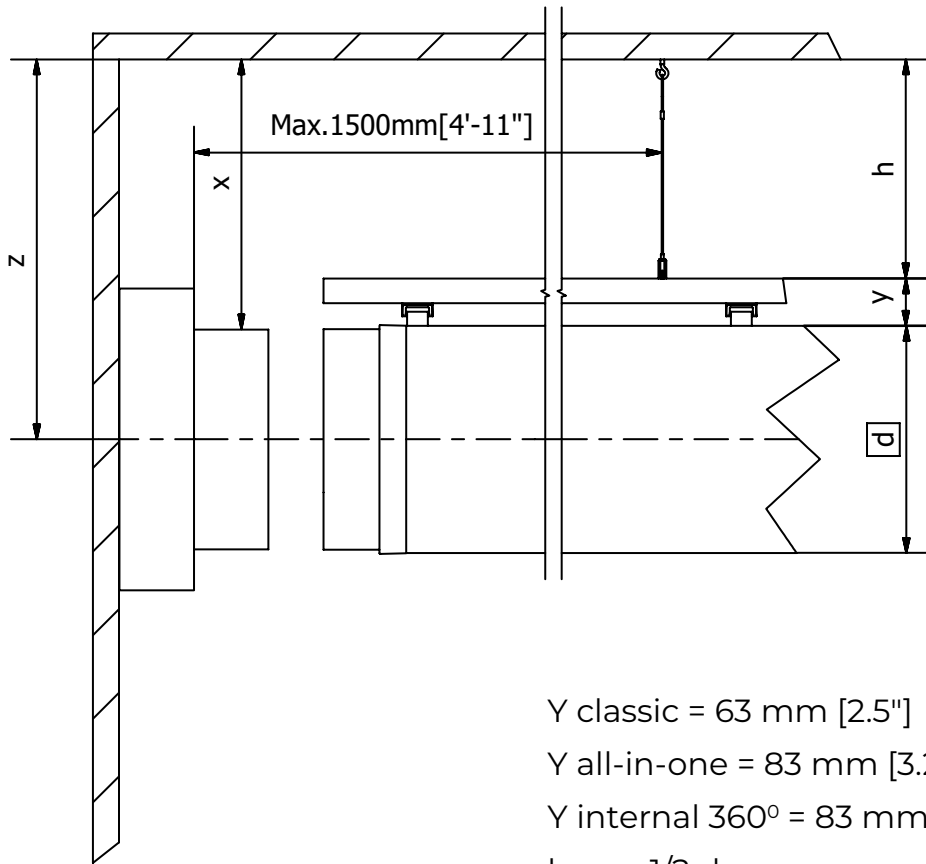

Y classic = 63 mm [2.5"]

Y all-in-one = 83 mm [3.25"]

Y internal 360° = 83 mm [3.25"]

$h = z - 1/2 d - y$

$h = x - y$

Strap lengths may be extended on Type 08 suspension, as needed to allow ducts to hang more than 50 mm [2"] below ceiling.

NOTE! Hardware quantities for vertical hangers are calculated based on 2 m [6'-7"] spacing. Installer must request additional hardware if vertical anchor spacing is to be less than 2 m [6'-7"].

Standard strap length for the 3 possible options:

classic: 30 mm [1.2"] minimum length;

All-in-One / Internal 360° Hoops: 50 mm [2"] minimum length.

2.2 Joining profiles

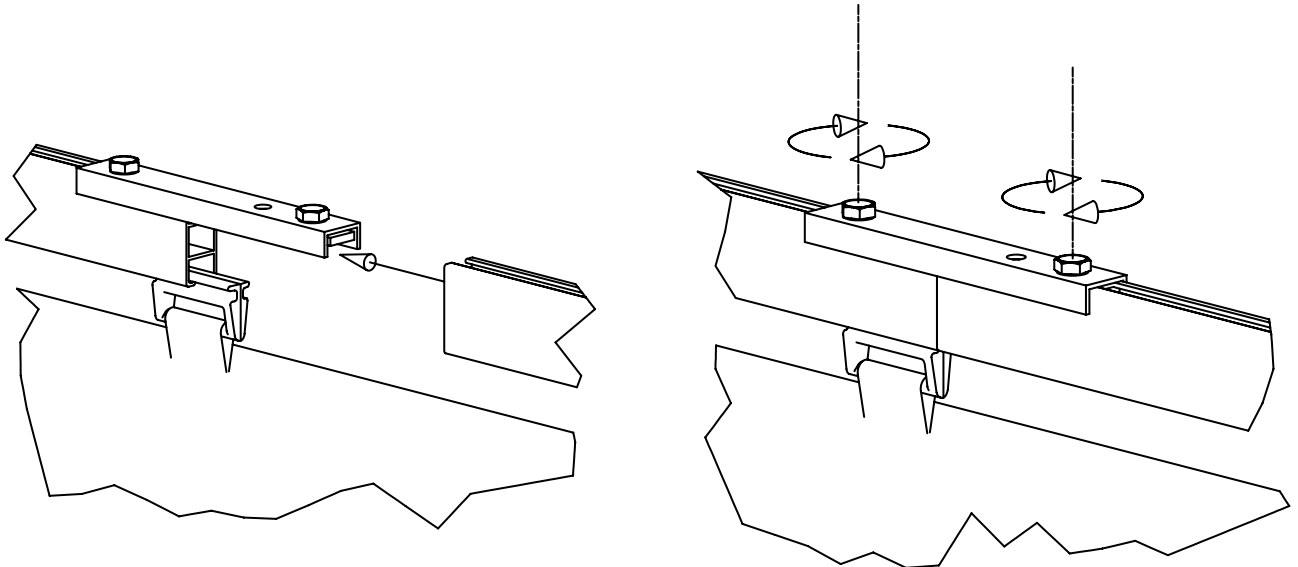

2.3 Connecting additional profiles

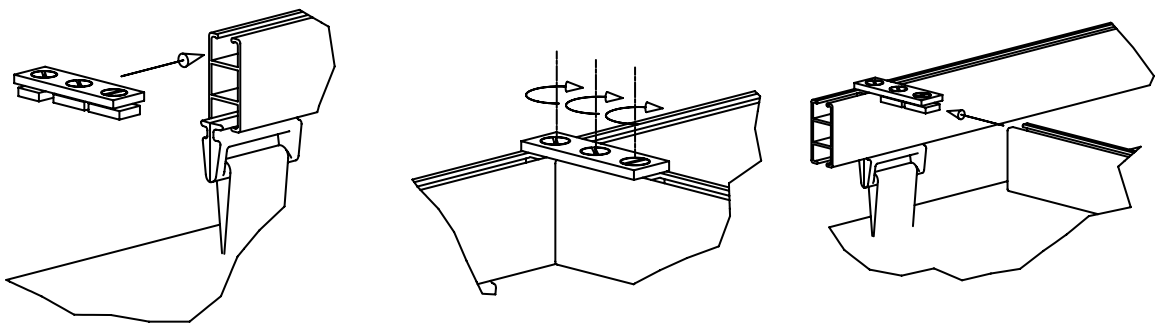

- H-Rail pieces are joined together using a metal connector.
- Connector secures to H-Rail with hex-bolts.
- Duct will have sliders or a bulb edge to slide into H-Rail at appropriate locations.
- Rails can be bent to the exact angle needed to suit elbows in FabricAir duct system.

2.4 Branches

Top aligned branch

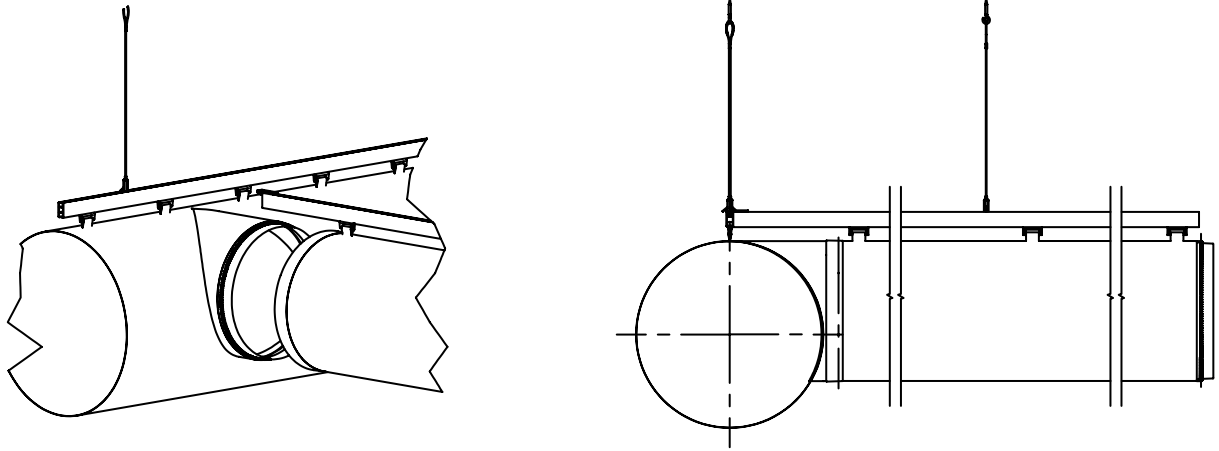

Middle aligned branch with extended strap length

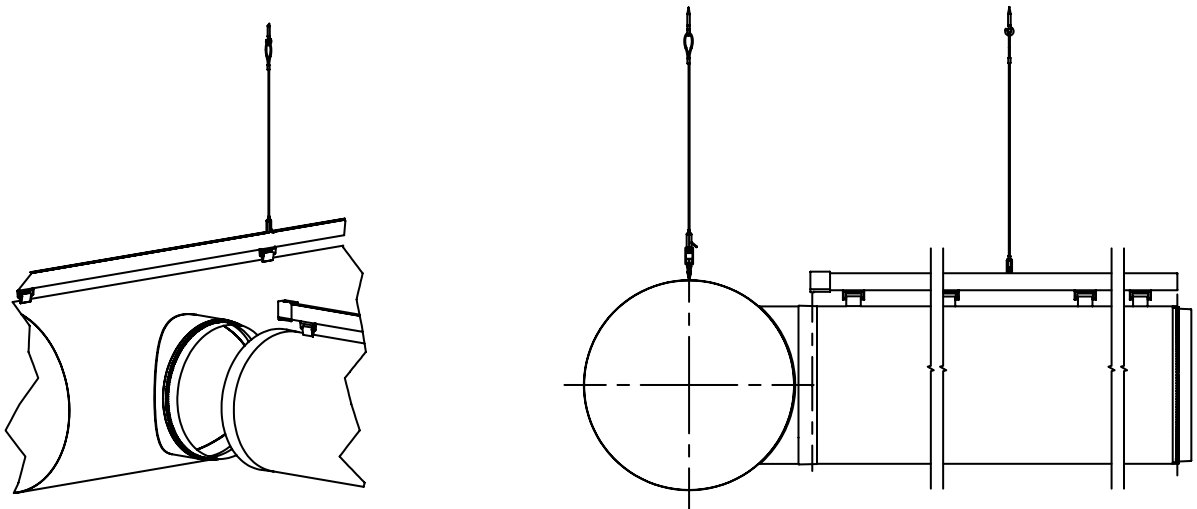

Bottom aligned branch with extended strap length

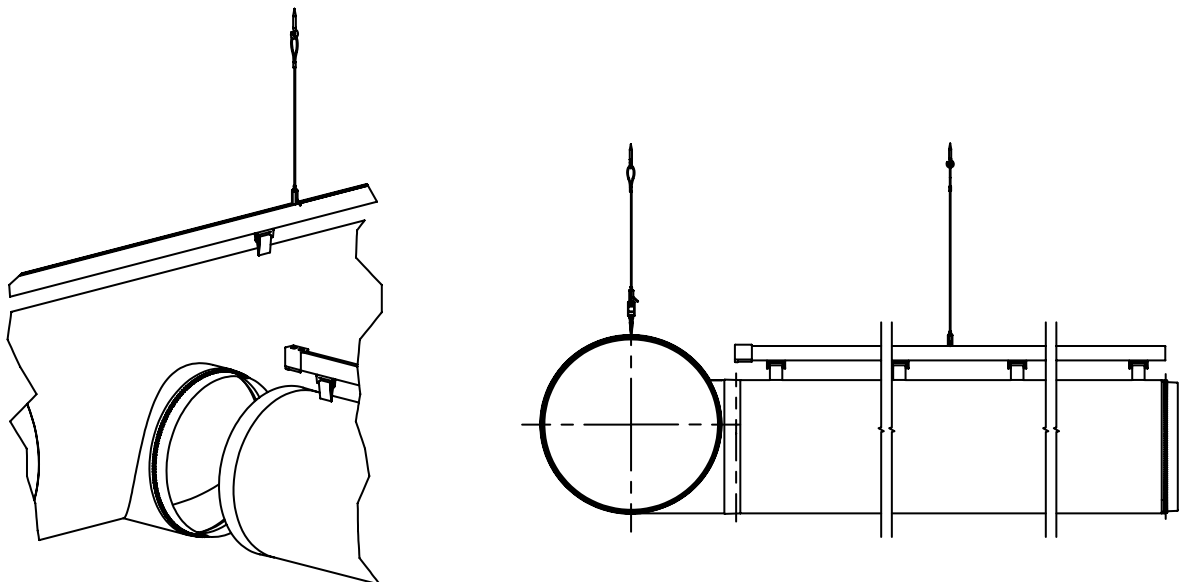

2.5 Detailed suspension installation details

Use QR code for more detailed information for each type.

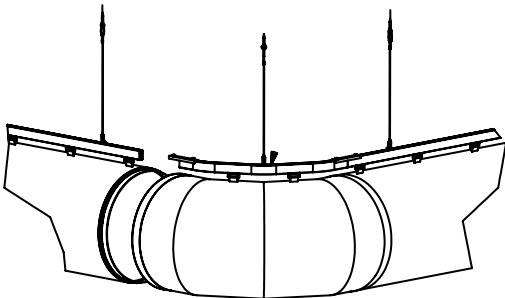

Bendings and elbows
All degrees and sizes

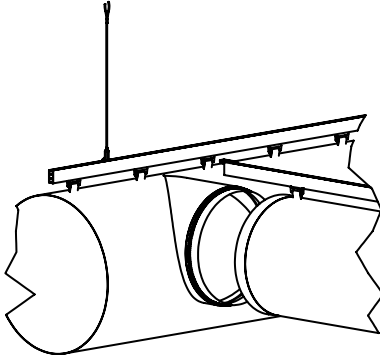

Branches
Top/center/bottom aligned

Drawings

Video

Drawings

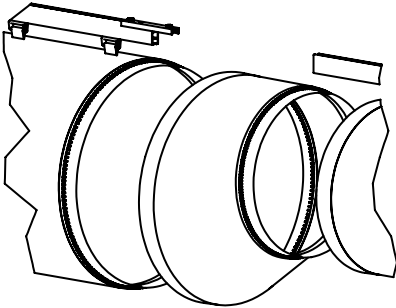

Reductions
Top/center/bottom aligned

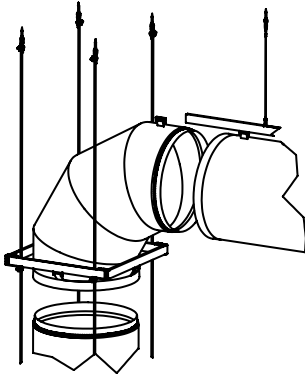

Vertical duct suspension methods

Drawings

Drawings

3.0 SHAPE RETAINING HARDWARE

Shape retention solution for Type 08 suspension.

Standard All-in-One strap length = 50 mm [2"].

Comes pre-installed from the factory.

Rods emerge from the side of the pocket, positioned towards the bottom.

3.1 All-in-One

Assembly

Disassembly

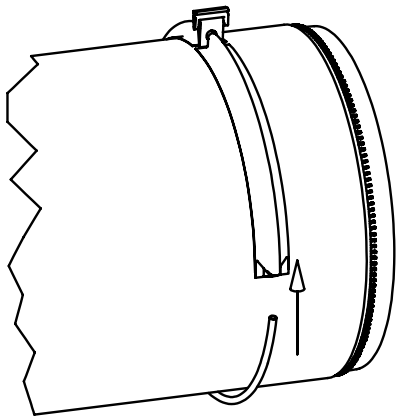

1

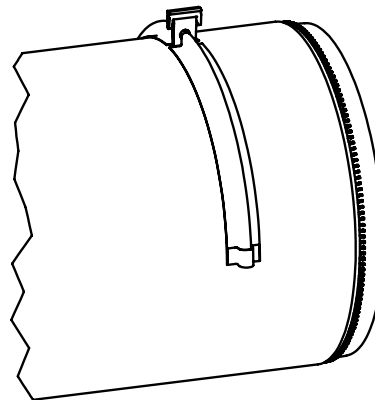

Video

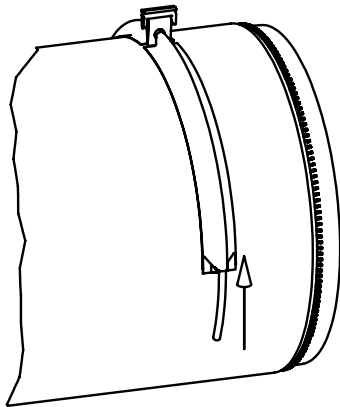

2

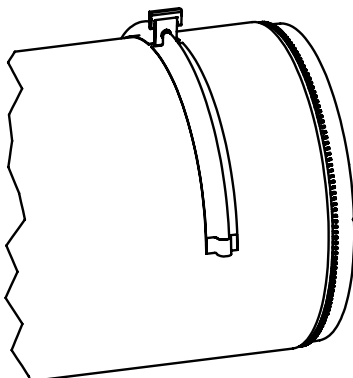
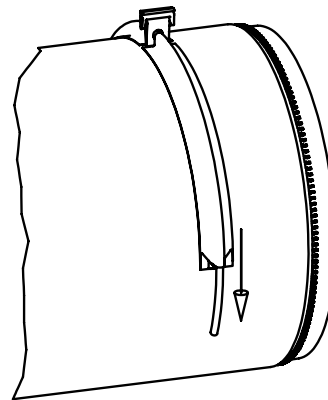

3

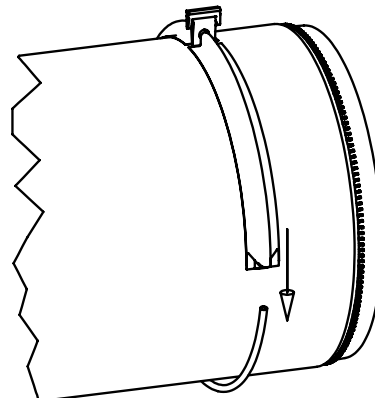

3.2 Internal 360° Hoops assembly

Optional shape retention solution for Type 08 suspension.

Standard 360° Internal Hoops strap length = 50 mm [2"].

Arrives from the factory: $\varnothing \leq 660$ mm [26"]

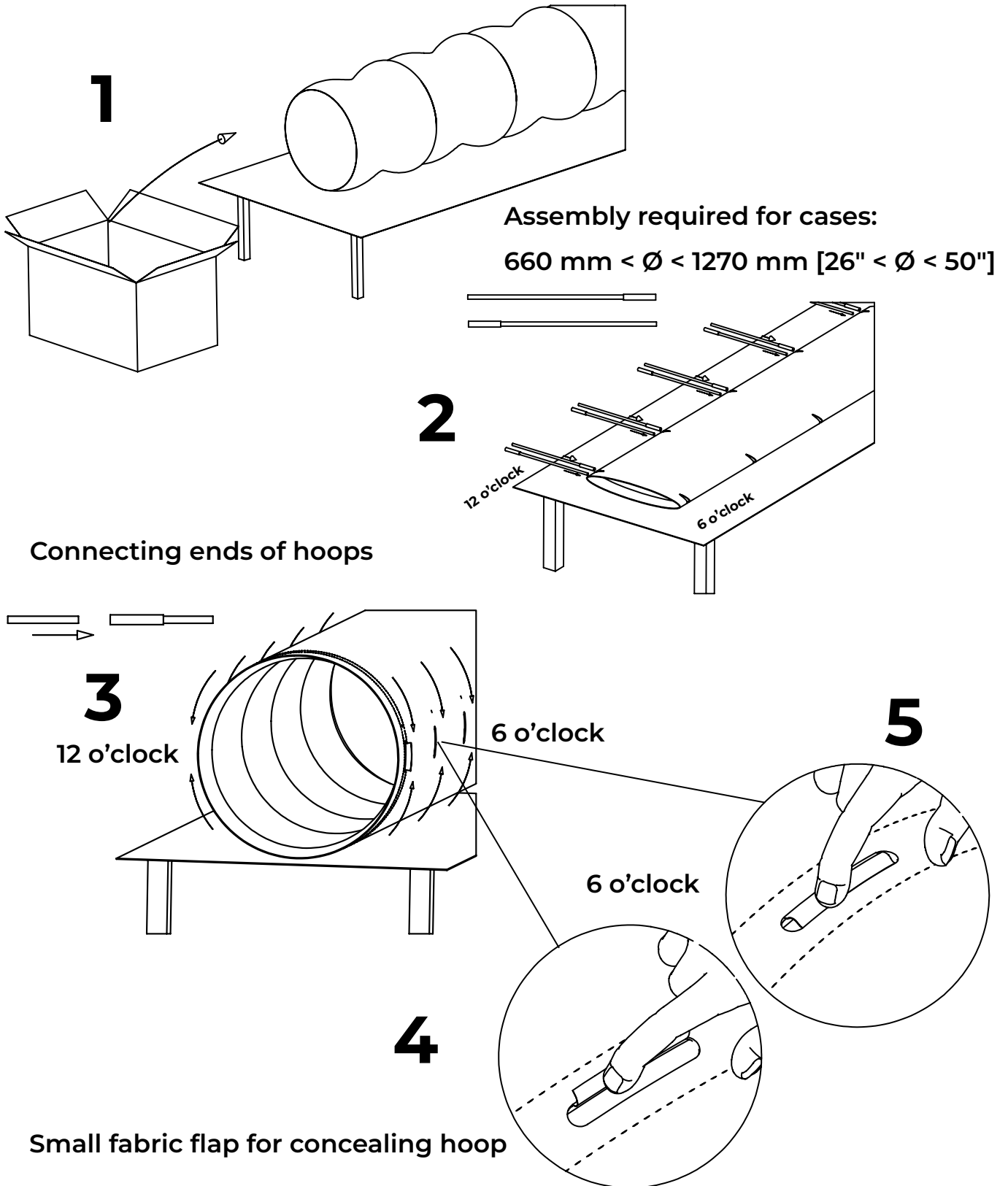

3.3 Internal 360° Hoops disassembly

To remove the internal hoops, ensure that the connectors are arranged at 6 and 12 o'clock.

Rotate the duct to access the hoop through the slotted access hole at 6 o'clock.

Press down to flatten the connection point and slide rod out of metal sleeve.

Rotate duct to access 12 o'clock access slot and repeat to remove.

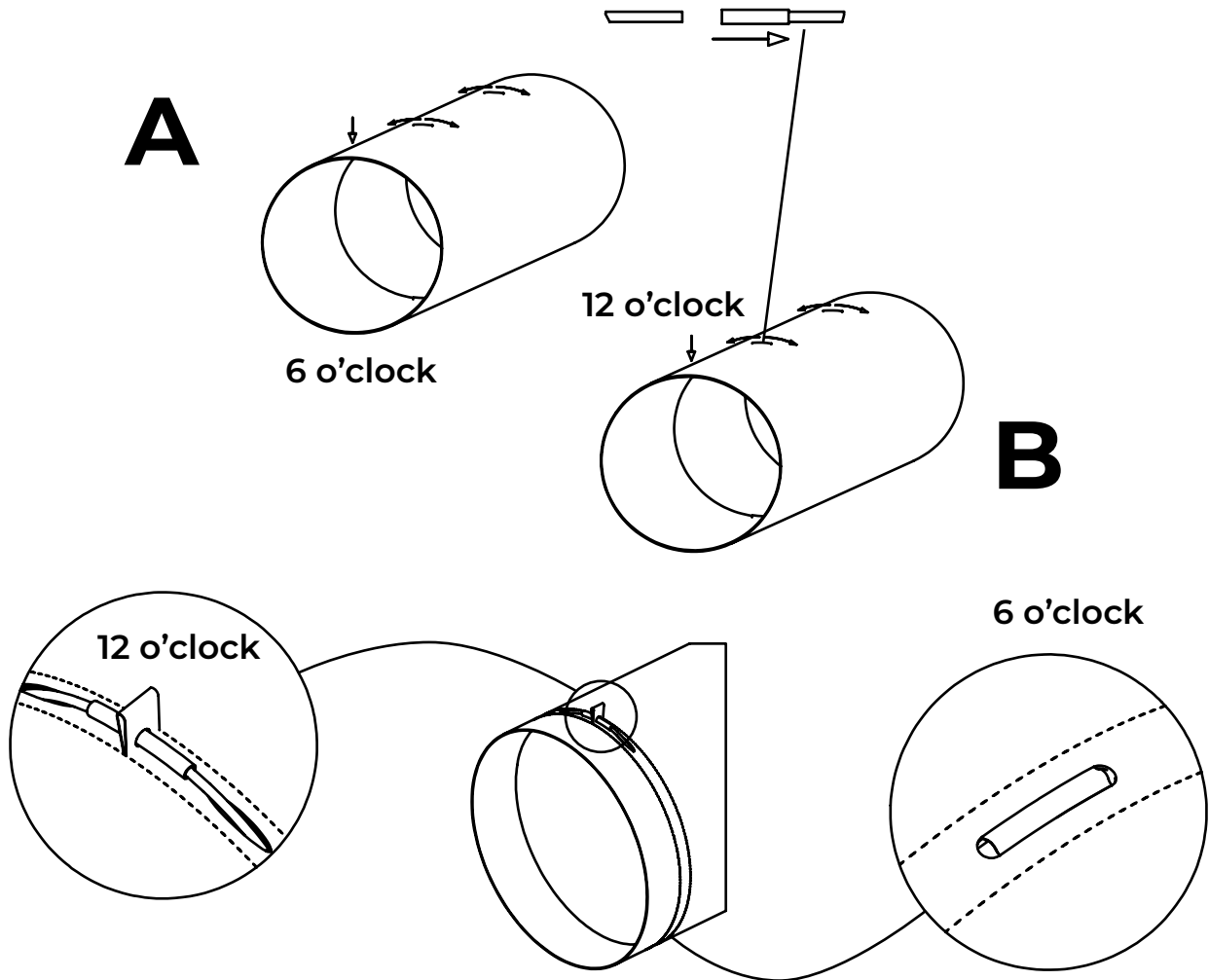

Deform circle to remove hoop.

While dismantling hoops, keep hoop connector at the 12 o'clock.

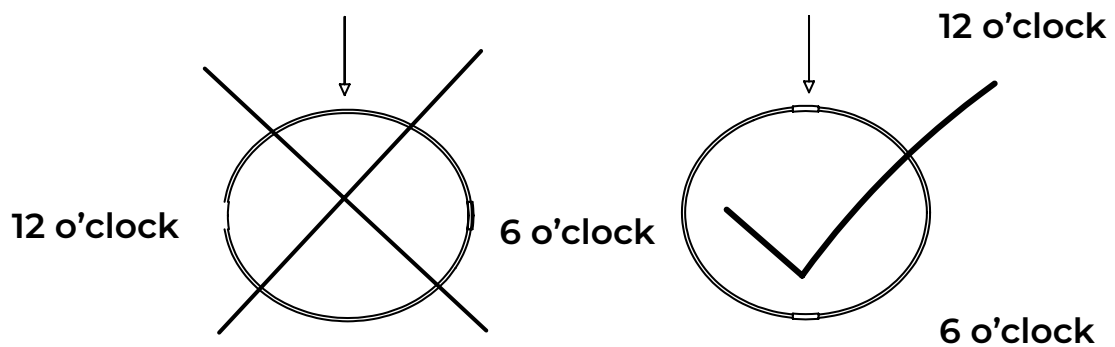

4.0 INSTALLING THE FABRIC

4.1 Connection to sheet metal part with fixing strap

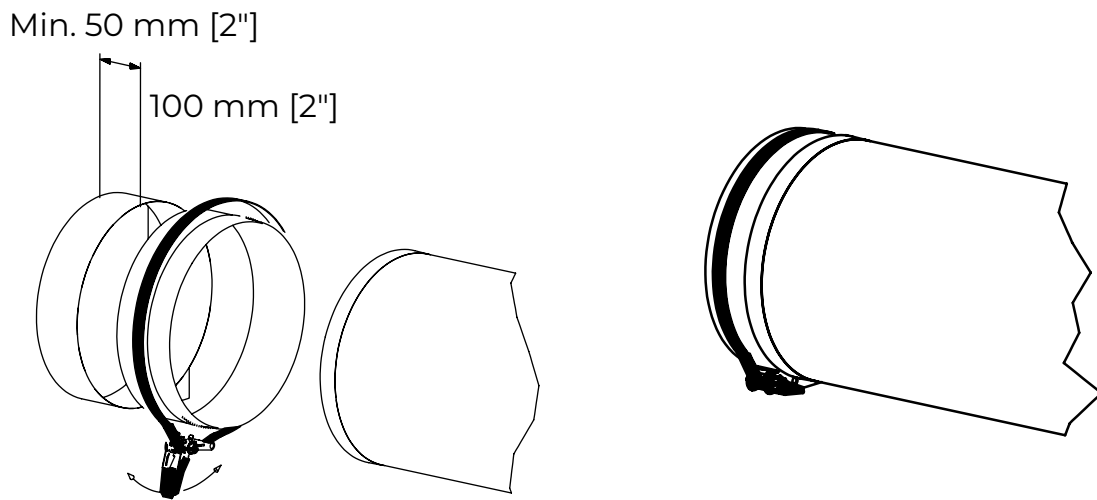

4.2 Fixing straps

Part ID (17) Duct $\varnothing < 510$ mm [20"]

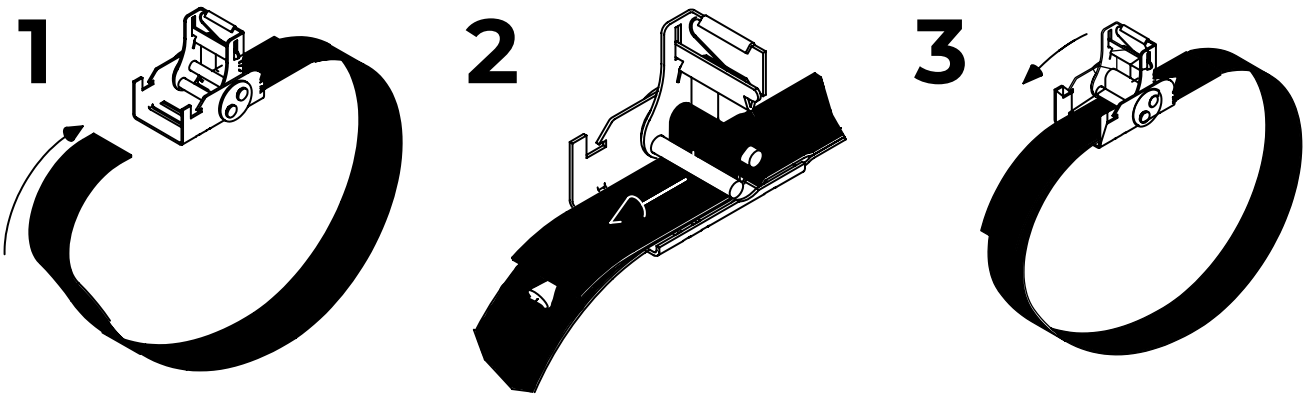

Part ID (18) Duct $\varnothing \geq 510$ mm [20"]

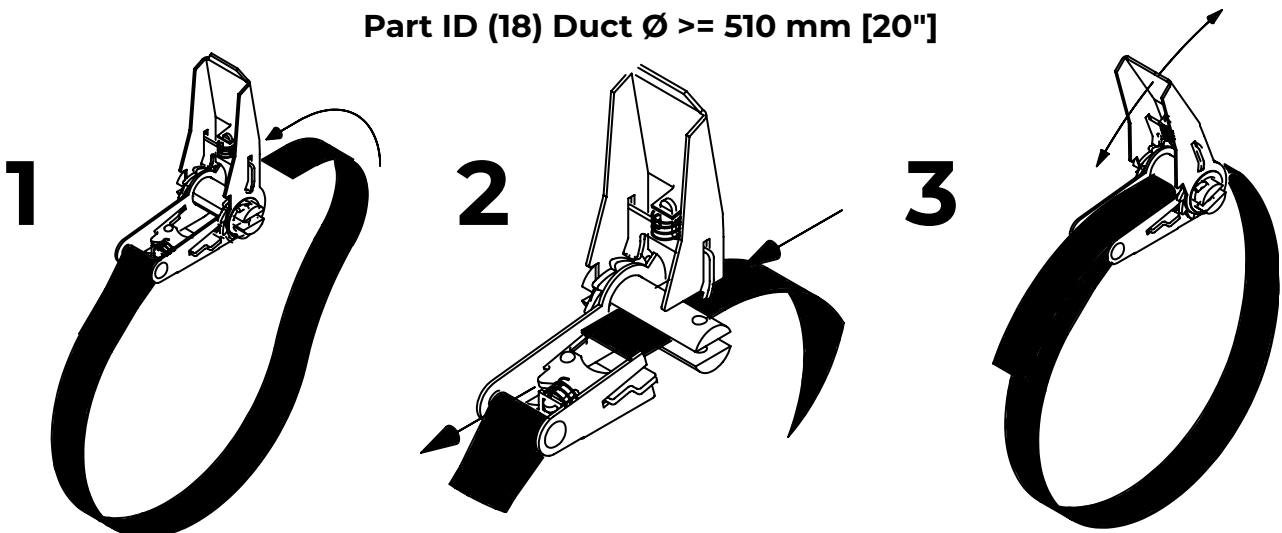

4.3 Installation of duct on H-Rail

1

Stretch the duct

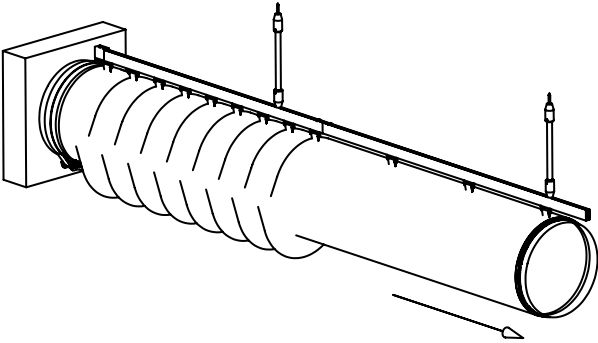

2

Hang ducting first

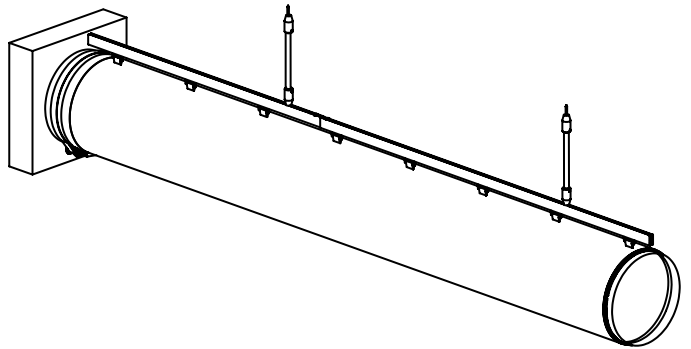

3

Insert hangers in the rail

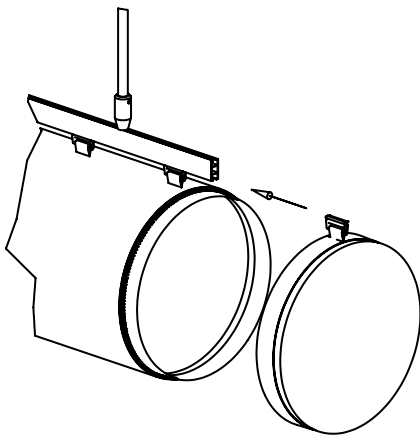

4

Slide endcap to the end of the duct. Zip it

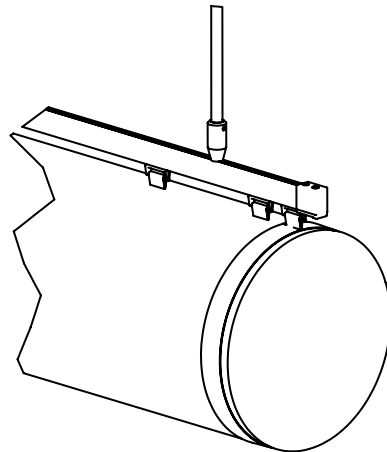

5

Secure duct by inserting profile lock

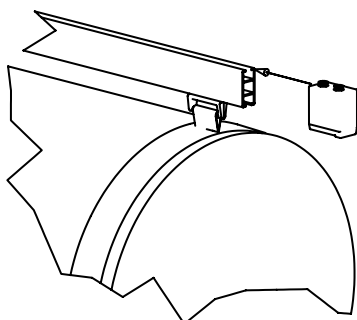

6

Fix profile lock by turning bolt clockwise

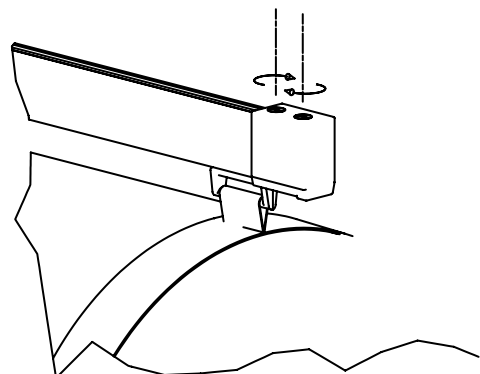

4.4 Taut Endcap installation

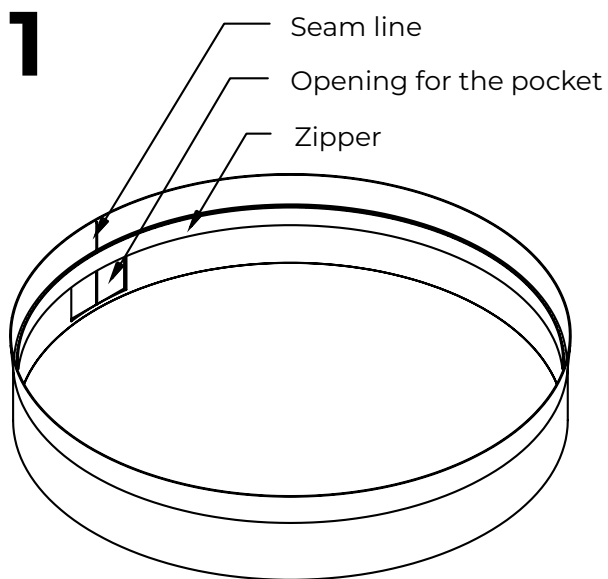

Lay the end cap flat on a clean surface

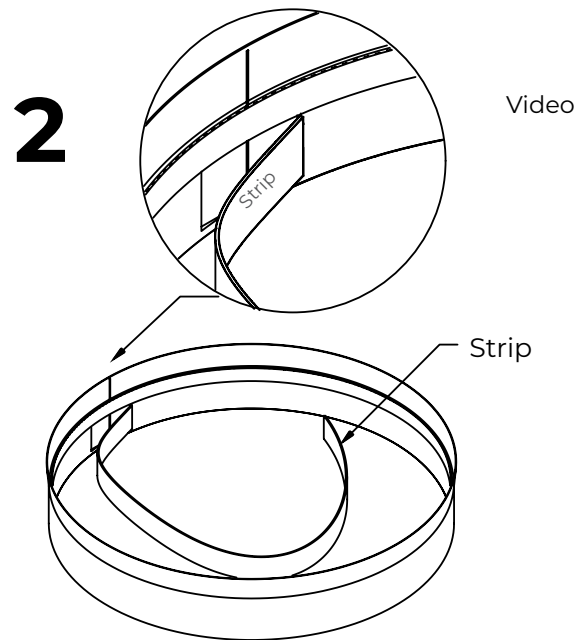

Insert the strip in the pocket all around the endcap

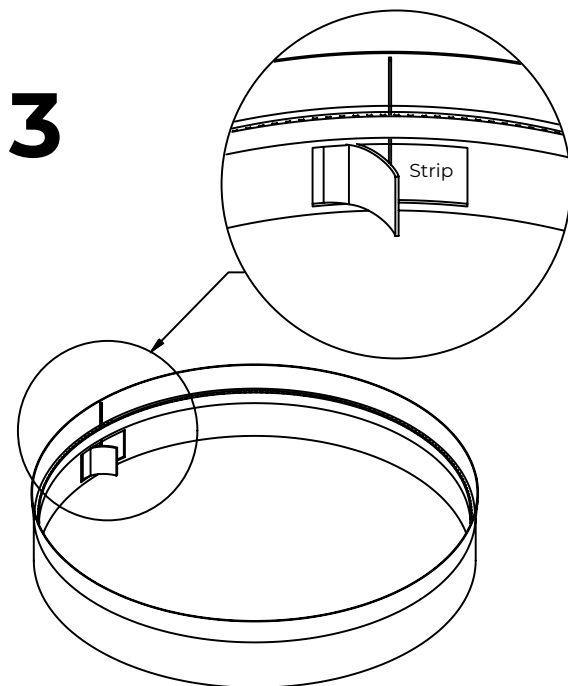

Align one end of the strip with the seam line

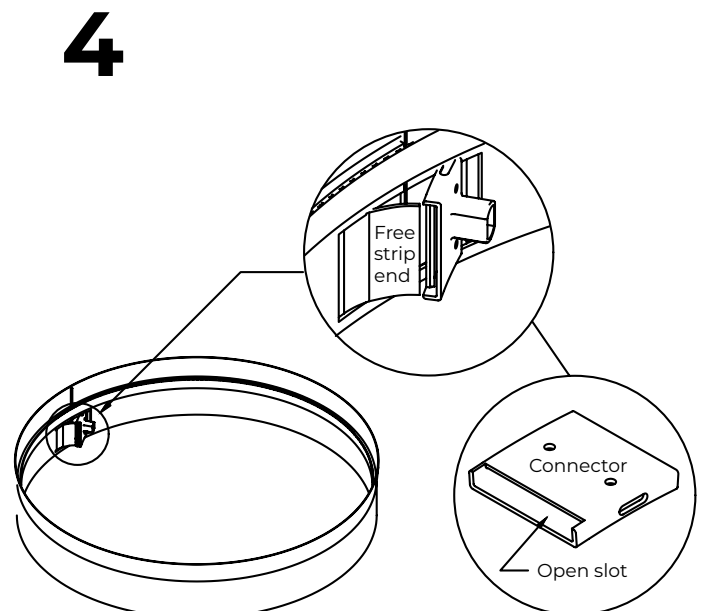

Put connector on the aligned strip end with the open slot towards the free strip end

5

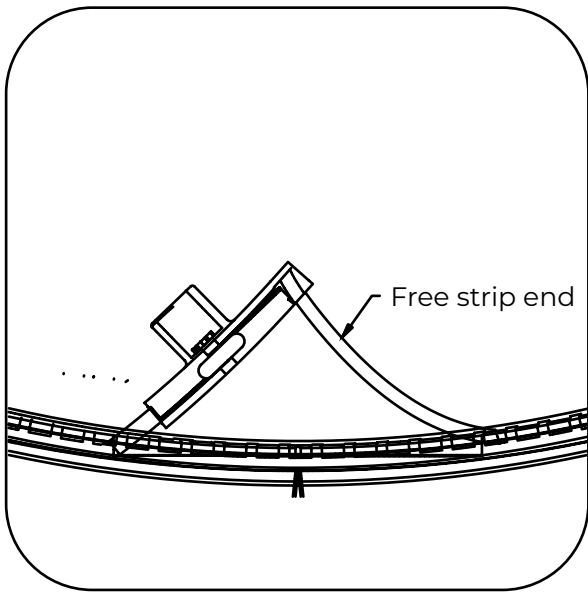

Place the free strip end in the open slot

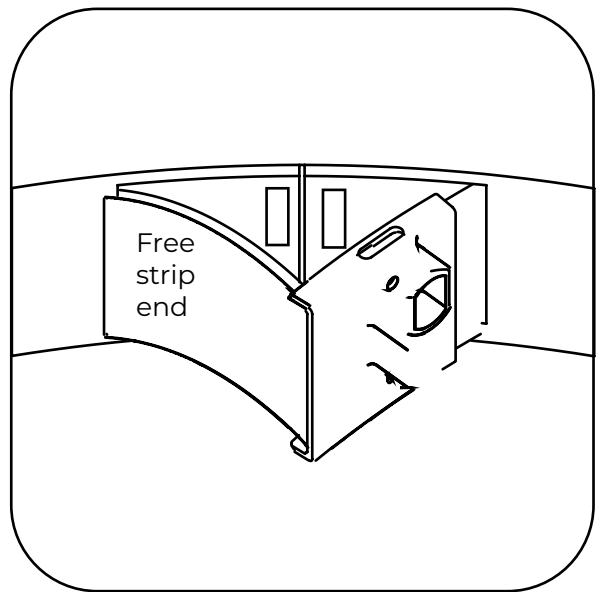

Hold the connector and the free strip end together and push until both strip ends are aligned

6

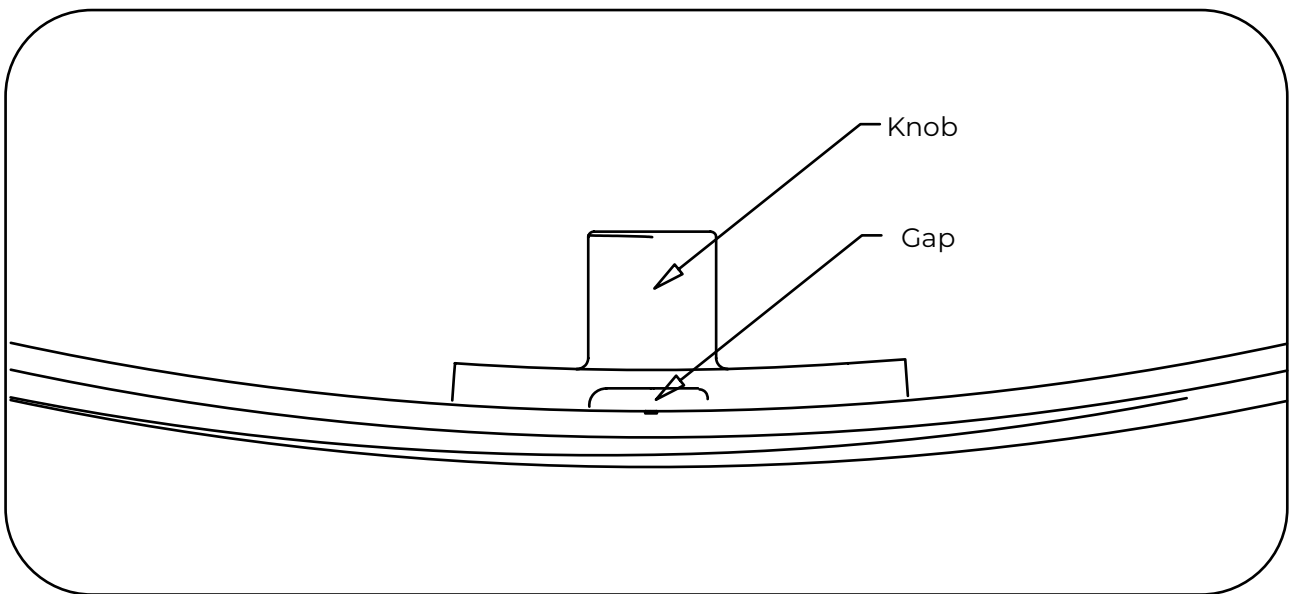

Using the knob, slide the connector and make sure the gap between both strip ends is in the center of the connector



fabricair.com/contacts/

All rights reserved to FabricAir®, 2023.
The latest version can be downloaded from fabricair.com
Version: 230809